

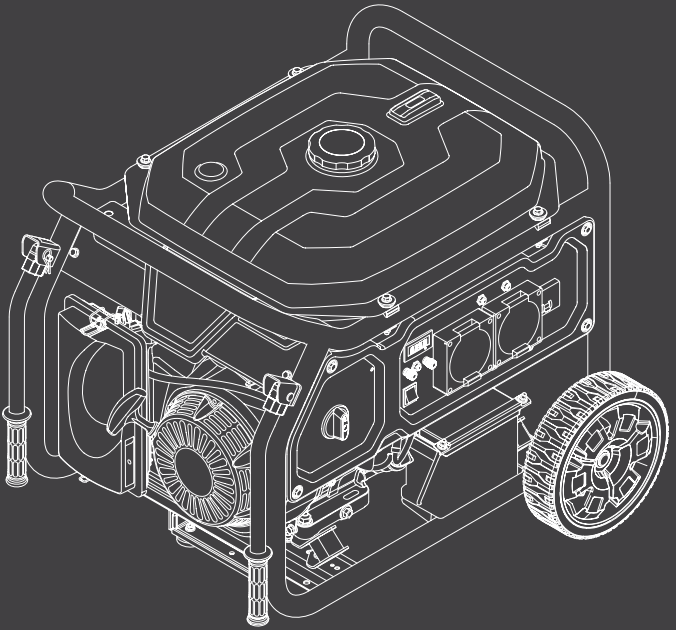

**CROMTECH**

6500W AVR GENERATOR



**CROMTECH AVR GENERATOR  
OPERATION MANUAL**

Thank you for purchasing a Cromtech Generator.

This manual provides understanding of the operation and maintenance of your generator. Please read this manual carefully before operating.

For any questions regarding operation or maintenance, please consult your local service agent. Find your local service agent at [www.crommelins.com.au](http://www.crommelins.com.au).

### IMPORTANT ICONS

Important information is distinguished by the notifications below. The Safety Alarm Symbol () alerts you to potential hazards. Please obey all safety information in the symbol to avoid any possible injury or even death.

 **DANGER:** - Indicates a hazardous situation which, if not strictly complied with, will result in substantial property damage, serious injury or DEATH.

 **WARNING:** Indicates a hazardous situation which, if not strictly complied with, may result in property damage,

 **CAUTION:** Indicates a hazardous situation which, if not strictly complied with, could result in property damage or injury.

 **NOTE:** Indicates important information to simplify operation and understanding.

 **WARNING: PLEASE READ AND UNDERSTAND THIS MANUAL BEFORE OPERATING THE GENERATOR.**

 **NOTE: We continually seek advancements in product design and quality. Therefore, there may be minor discrepancies in actual machine and the printed manual.**

## INDEX:

<b>Warranty</b> .....	<b>4</b>
<b>Safety Warnings</b> .....	<b>5</b>
<b>TG6500VE Diagram</b> .....	<b>8</b>
Main features .....	9
Control panel .....	9
<b>Generator specifications</b> .....	<b>9</b>
<b>Getting started</b> .....	<b>10</b>
Unpacking .....	10
Assembly .....	10
<b>Battery and Parts</b> .....	<b>12</b>
<b>Operating Checklist</b> .....	<b>13</b>
Operating area .....	13
Operating condition .....	13
<b>Check engine oil</b> .....	<b>14</b>
<b>Check fuel levels</b> .....	<b>15</b>
<b>Electrical devices</b> .....	<b>16</b>
<b>Grounding</b> .....	<b>16</b>
<b>Starting the generator</b> .....	<b>17</b>
Connecting electrical devices .....	19
Maximum capacity .....	19
Wattage reference guide .....	20
Charging a battery .....	21
Stopping the generator .....	22
<b>General maintenance</b> .....	<b>23</b>
Maintenance schedule .....	24
Generator maintenance .....	24
Engine oil .....	25
Air filter .....	26
Spark plug .....	27
Spark arrestor .....	28
Engine speed .....	28
Adjustments .....	28
<b>Troubleshooting</b> .....	<b>29</b>
<b>Storage and transport</b> .....	<b>29</b>
Storage .....	29
Long term storage .....	29
Transport .....	30

## **WARRANTY**

CROMTECH™ and CROMMELINS™ are a registered trademark of The Crommelin Group. Crommelins warrants their goods against defects in materials and workmanship under normal use and service.

The Crommelin Group warranty does not cover fair wear commensurate with the age of the product, any damage caused by accident, abuse, misuse, neglect or failure to observe proper operating instructions or proper machinery maintenance as described in the instruction manual.

It is the owner's responsibility to regularly maintain a product in accordance with the owner's manual and only use the equipment for its designed purpose.

Our goods come with guarantees that cannot be excluded under the Australian Consumer Law. You are entitled to a replacement or refund for a major failure and for compensation for any other reasonably foreseeable loss or damage. You are also entitled to have goods repaired or replaced if the goods fail to be of acceptable quality and the failure does not amount to a major failure.

## **CONSUMER ADVICE**

Any claim under these warranties must be made in the warranty period from the date of purchase of the product.

There are over 185 national authorised service/repair agents available, visit [www.crommelins.com.au](http://www.crommelins.com.au) for their details and locations.

To make a claim under the warranty, you must return the product (with proof of purchase) to the closest warranty agent or to the place of purchase.

Where a failure does not amount to a major failure, Crommelins Machinery is entitled to choose between providing you with a repair, replacement or refund. To obtain compensation, you would need to provide documentary evidence of the loss or damage suffered, and documentary evidence that such loss or damage was a reasonably foreseeable consequence of a failure by The Crommelins Group to comply with a consumer guarantee under the Australian Consumer Law.

Crommelins Operations Pty Ltd trading as The Crommelin Group,  
Crommelins Australia and Crommelins Machinery

## **THE CROMMELIN GROUP:**

Ph: (08) 9350 5588 Fax: (08) 9451 6381

[reception@crommelins.com.au](mailto:reception@crommelins.com.au)

[www.crommelins.com.au](http://www.crommelins.com.au)

PO Box 352, BENTLEY WA 6982

ABN 11 008 889 656

## SAFETY WARNINGS

**⚠ WARNING: DO NOT Operate this generator until you have read ALL safety, operation, and maintenance instructions listed in this manual.**

- Failure to follow the instructions may result in property damage, INJURY or DEATH.
- The warnings and precautions discussed in this manual cannot cover all possible conditions and situations that may occur. It must be understood by the operator that common sense and caution are factors which cannot be built into this product, but must be supplied by the operator.

**⚠ WARNING: Modifications to any part of the generator is not allowed and may void your warranty.**

**⚠ WARNING: This generator is intended for residential consumer use only. This generator is not designed for permanent setup.**

**⚠ WARNING: Before each use, check for loose or damaged parts, signs of oil or fuel leaks, and any other condition that may affect proper operation. Repair or replace all damaged or defective parts immediately.**

- Locate all operating controls and safety labels.
- Operate only on level surfaces.
- DO NOT expose generator to excessive moisture, dust, or dirt.
- Keep all safety guards in place and in proper working order at all times.
- DO NOT allow any material to block the cooling slots.
- DO NOT allow children or untrained persons to operate the generating set.
- DO NOT run the generating set unattended. Turn off the generating set before leaving the area.

**⚠ DANGER: FIRE OR EXPLOSION - Gasoline is highly flammable and extremely explosive.**

- Fire or explosion can cause severe burns or death.
- Keep flammable items away while handling gasoline.
- Fill fuel tank outdoors and in a well-ventilated area with the generator stopped.
- Always wipe off spilled fuel and wait until the fuel has dried before starting the generator.

- DO NOT operate the generator with known leaks in the fuel system.
- Use proper fuel storage and handling procedures. DO NOT store fuel or other flammable materials nearby.
- Empty the fuel tank before storing or transporting the generator.
- Keep fire extinguisher handy and be prepared if a fire starts.

**⚠ DANGER: TOXIC FUMES - The exhaust of the generator engine contains carbon monoxide, an odorless, colorless, poison gas. Using engine indoors CAN KILL YOU!**

- NEVER use generator inside any building or any kind of enclosure, EVEN IF doors and windows are open.
- Place the generator in a well-ventilated area and consider wind and air currents when positioning the generator

**⚠ DANGER: MOVING PARTS - Moving parts can cause severe injury. Keep hands and feet away.**

- DO NOT operate generator with covers, shrouds, or guards removed.
- DO NOT wear loose-fitting clothing, dangling drawstrings or items that could become caught. Tie up long hair and remove jewelry.
- NEVER place fingers, hands, or body near the engine when it is running.

**⚠ DANGER: KICKBACK - Rapid retraction of the starter cord will pull hand and arm towards the engine faster than you can let go.**

- Unintentional startup could result in an injury.

**⚠ WARNING: HOT SURFACE - The running generator produces heat. Severe burns can occur on contact.**

- DO NOT touch generator while operating or just after stopping. Avoid contact with hot exhaust gases.
- Maintain at least three feet of clearance on all sides to ensure adequate cooling.
- Combustible material can catch fire on contact. Maintain at least one metre of clearance from combustible materials.

**⚠ WARNING: ACID (For types equipped with battery) - Be careful when using any battery.**

- Keep away from open flame, heat or spark.
- Battery will exhaust hydrogen while charging. Only

charge a battery in a well ventilated place.

- Avoid spilled battery acid. If contact with skin is made, wash immediately with clean water.



**WARNING: ELECTRICAL SHOCK - This generator produces powerful voltage and the electricity CAN KILL YOU.**

- This generator must be properly connected to an appropriate ground to help prevent electric shock. Failure to properly ground generator can result in electrocution, especially if the generator is equipped with a wheel kit. Consult an electrician for local grounding requirements.
- To reduce the risk of electrical shock, DO NOT use electrical cords that are worn, frayed, bare or otherwise damaged.
- DO NOT touch bare wires or receptacles.
- DO NOT operate generator in wet weather. Keep the generator dry.
- DO NOT handle generator or electrical cords while standing in water, while barefoot, or while hands or feet are wet.
- DO NOT allow unqualified persons or children to operate or service the generator.

# TG6500VE DIAGRAM

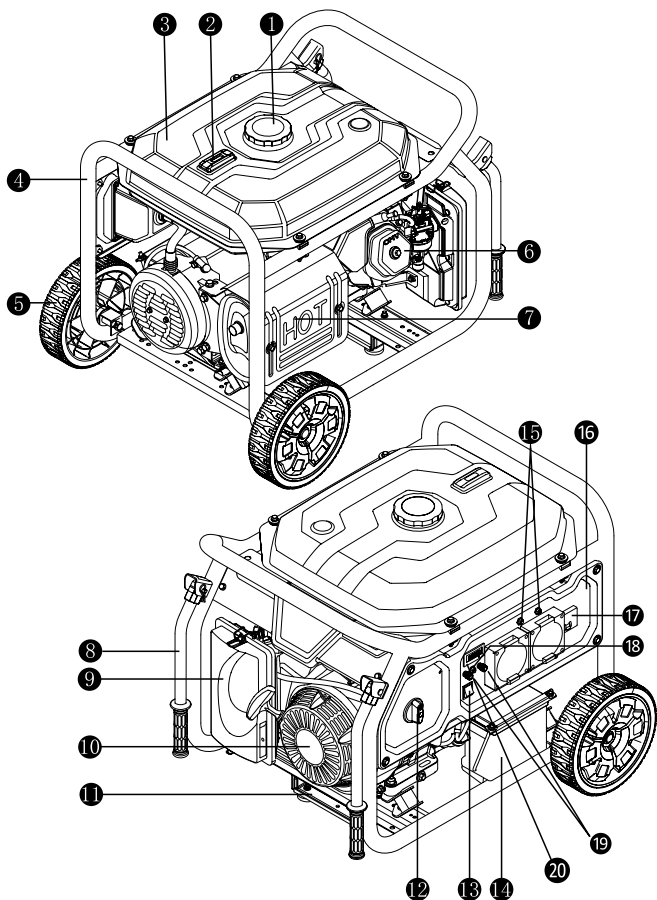

- |                        |                    |                             |
|------------------------|--------------------|-----------------------------|
| 1 Fuel cap             | 8 Push handle      | 15 AC Overload reset button |
| 2 Fuel level indicator | 9 Air filter       | 16 Control panel            |
| 3 Fuel tank            | 10 Recoil starter  | 17 RCD Circuit breaker      |
| 4 Frame                | 11 Support bracket | 18 DC Overload reset button |
| 5 Wheels               | 12 Fuel switch     | 19 DC Battery charging      |
| 6 Cylinder head        | 13 Engine switch   | 20 VFT Metre                |
| 7 Muffler guard        | 14 Battery         |                             |

## CONTROL PANEL

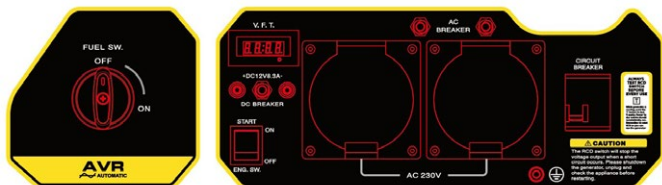



## GENERATOR SPECIFICATIONS

Model	TG6500VE
Max. Output (W)	6500w
Cont. Rated Output (W)	6000w
Rated Voltage	230V / 50Hz
Power Factor	1.0
Engine	10hp Cromtech
Engine Features	OHV, air cooled
Displacement	420cc
Fuel Type	Petrol
Fuel Tank	25L
Running Time (75% load)	11 Hours
Oil Capacity	1.1L
Decibels at 7m (db)	74db
Weight (kg)	87kg
Packaging (LxWxH)	715x545x605mm

## FEATURES

- 2x Outlets (single phase - 15 Amp)
- Weatherproof outlets (IP66)
- Electric start and recoil start
- Fold-out handles
- Steel frame with large wheels
- 4-Stroke, air cooled, OHV engine
- Large 25L fuel tank
- 10hp Cromtech engine (420cc)
- VFT Metre (Volts, Frequency, Time)
- Battery charging (12V-8.3Amp)
- Low oil alarm, overload alarm, output indicator
- One-year Cromtech warranty

## GETTING STARTED

**!** **NOTE: DO NOT** Operate this generator until you have read **ALL** safety, operation, and maintenance Instructions listed in this manual.

1. UNPACKING - Remove the generator from the shipping carton
  - i. Place the shipping carton on a solid, flat surface.
  - ii. Carefully cut each corner of the carton box from top to bottom. Fold each side flat on the ground.
  - iii. Remove everything from the carton except the generator.
2. ASSEMBLY - Your generator requires some assembly. If you have any questions regarding the assembly of your generator, please have your model number and serial number ready and consult your local dealer for help.

**INSTALL WHEEL KIT** - Put wheel stop pin through wheel and mounting lug hole, then fix it with the clip.

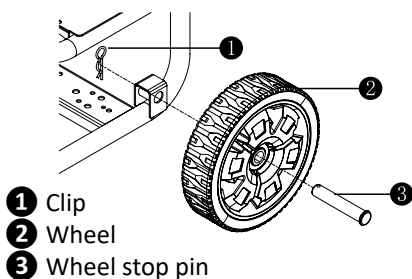

**INSTALL SUPPORT BRACKET** - Connect bracket nuts, seats, support bracket and bolt to frame.

- 1** Support bracket nut M8
- 2** Damping seat nut M6
- 3** Support bracket
- 4** Damping seat
- 5** Damping seat nut M6 x18
- 6** Support bracket bolt M8 x16

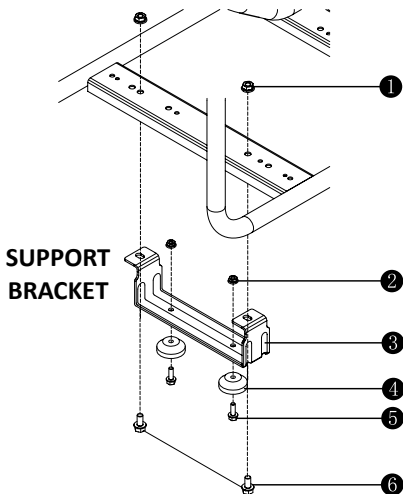

**INSTALL THE HANDLE** - Place the push handle in the bracket. Push the pin through the bracket and handle and fix with the clip provided.

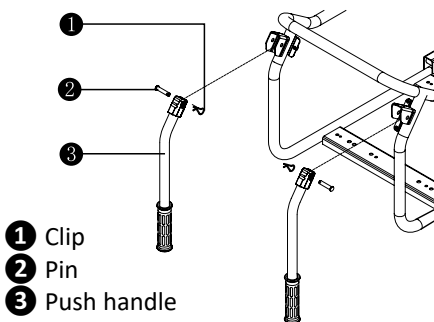

**ATTACH NEGATIVE BATTERY WIRE** - The sealed battery on the generator is fully charged and pre-installed except for the negative (black) battery cable.

1. Cut off tie wrap securing loose end of negative (black) cable.
2. Connect the negative (black) battery cable to the negative(-) terminal on the battery.
3. Verify if it is correct and secure the connections between the battery and generating set.

- 1** Positive (+) terminal (red)
- 2** Negative (-) terminal (black)

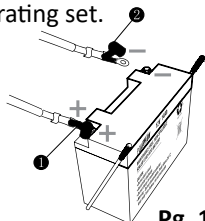

## OPERATING CHECKLIST

1. *OPERATING AREA* - This generator is for outdoor use.

- Only use OUTSIDE and place the generator in a well-ventilated area.
- Only operate the generator on a flat, level surface and in a clean, dry operating environment.
- Allow one metre clearance on all side of the generator while operating it outdoors.
- Generators used for construction sites may be subject to additional rules and regulations.

 **DANGER: TOXIC FUMES** - The exhaust of the generating set contains carbon monoxide, an odorless, colourless, poison gas. Using engine indoors **CAN KILL YOU**.

- **NEVER use inside any building or any kind of enclosure, EVEN IF doors and windows are open.**
- **Place the generator in a well-ventilated area and carefully consider wind and air currents when positioning generator.**

2. *OPERATING CONDITION* - Check for loose or damaged parts, signs of oil or fuel leaks, and any other condition that may affect proper operation. Repair or replace all damaged or defective parts immediately.

- Remove any excessive dirt or debris, especially around the muffler and recoil starter.
- **DO NOT** move or tip the generator during operation.

Use generator only for intended uses. If you have questions about intended use, ask your local dealer.

 **DANGER: Failing to correct problem(s) before operation could result in property damage, serious injury or DEATH.**

## CHECK ENGINE OIL

**!** **WARNING:** This engine is not filled with oil from the factory. Any attempt to crank or start the engine before it has been properly filled (with the recommended type and amount of oil) may result in engine damage and void your warranty.

1. **ENGINE OIL** - Place the generator on a level surface with engine stopped.
  - Remove the dipstick and wipe it clean.
  - Reinstall dipstick into tube; rest on oil fill neck, DO NOT thread cap into tube.

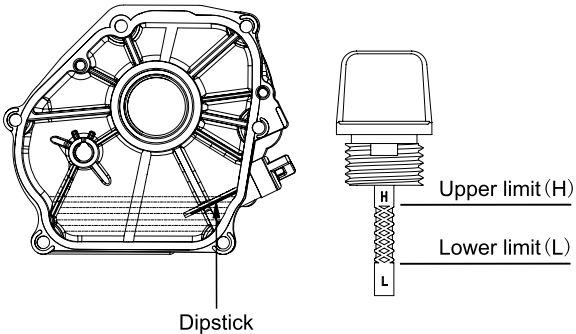

2. Remove the dipstick again and check oil level. Level should be at top of indicator on dipstick.
3. If lower, fill to the upper limit (marked with "H") of the dipstick with the recommended oil. Reinsert and fully tighten the dipstick.

**!** **WARNING:** Oil is a major factor affecting performance and service life of an engine. Use 4-stroke automotive oil SAE10W-30.

**!** **CAUTION: LEVEL GROUND** - Operate generator only on leveled surface. The engine is equipped with a low oil sensor (applicable types) that will automatic stop the engine when the oil level falls below the safe limit. To avoid the inconvenient of an unexpected shutdown, fill to the upper limit and check the oil level regularly.

## CHECK FUEL LEVELS

**⚠ CAUTION: Pressure can build up in the fuel tank. Allow the generator to cool for at least two minutes before removing fuel cap. Loosen the fuel cap slowly to relieve any pressure in the tank**

- **ENGINE FUEL** - With the engine stopped, check the fuel level gauge. Refill the fuel tank if necessary.
- Use clean, fresh, regular unleaded gasoline only.
- DO NOT mix oil with gasoline.
- Be sure not to fill above the upper limit mark, always fill to the level indicator, or fill to 25mm left from fuel tank (to allow room for fuel expansion).

**⚠ DANGER: FIRE OR EXPLOSION - Gasoline is highly flammable and extremely explosive. A fire or explosion can cause severe burns or death.**

- **Keep flammable items away while handling gasoline.**
- **Fill fuel tank outdoors and in a well-ventilated area with the engine stopped.**
- **Always wipe off spilled fuel and wait until the fuel has dried before starting the engine.**
- **DO NOT operate the engine with known leaks in the fuel system.**
- **Use proper fuel storage and handling procedures. DO NOT store fuel or other flammable materials nearby.**
- **Empty the fuel tank before storing or transporting this engine.**
- **Keep fire extinguisher handy and be prepared if a fire starts.**

**⚠ CAUTION: NEVER use engine or carburetor cleaner products in the fuel tank or permanent damage may occur.**

- It is important to prevent gum deposits from forming in fuel system, such as the carburetor, fuel filter, fuel hose or tank during storage. Also, any alcohol-blended fuels (called gasohol, ethanol or methanol) can attract moisture, which leads to separation and formation of acids during storage.
- Acidic fuel can damage the fuel system of an engine while in storage. Be sure to review the Storage instructions.

- Gasoline/Alcohol Blends: up to 10% alcohol, 90% unleaded gasoline by volume is approved as a fuel. Other gasoline/alcohol blends are not approved. Effects of old, stale or contaminated fuel may void your warranty.

**⚠ CAUTION: To minimise gum deposits in your fuel system and to insure easy starting, do not use gasoline left over from the previous season.**

## **ELECTRICAL DEVICES**

**⚠ NOTE: Disconnect all electrical devices from the generator and switch off the AC circuit breaker before start the engine.**

- The generating set may be hard to start with electrical devices.

## **GROUNDING**

**⚠ WARNING: ELECTRIC SHOCK - Failure to properly ground the generator can result in electric shock.**

- The generator must be properly connected to an appropriate ground. It helps prevent electrical shock if a ground fault condition exists in the generator or in connected electrical devices, especially when the unit is equipped with a wheel kit.
- Proper grounding also helps dissipate static electricity, which often builds up in ungrounded devices.
- A ground terminal on control panel generator has been provided. For remote grounding, connect of a length of heavy gauge(4mm) copper wire between the generator ground terminal and a copper rod driven into the ground.
- Your local state electrical codes may require proper grounding of the unit. We strongly recommend that you consult with a qualified electrician for grounding requirements in your area.

## STARTING THE GENERATOR

1. Perform the operating checklist (page 12).
2. Turn the fuel valve to the 'ON' position

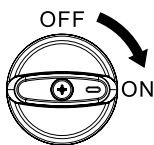

Fuel valve

3. Put the choke valve switch to 'CLOSE' position

**! NOTE: Choke position for starting may vary depending upon temperature and other factors. If re-starting a warm engine, the choke should be left in the HALF or OFF position.**

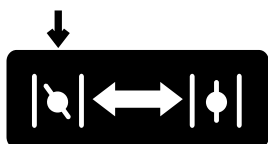

CLOSE

OPEN

4. ELECTRIC START - Push the rocker ignition switch to 'I' run position. Then push fully and hold switch in 'II' position until the engine is started. After the engine is started, release the button (It will return to the 'I' run position).

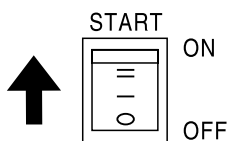

Electric start

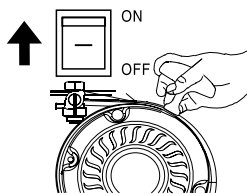

Manual start

5. MANUAL START - Turn the rocker ignition switch to the 'I' run position. Then take hold of the recoil handle and slow pull until there is a sense of resistance, and then quickly pull to start.

**! CAUTION: Ensure that the recoil rope is not damaged and repair if required.**



**! WARNING:** Rapid retraction of the starter cord will pull hand and arm towards the engine faster than you can let it go. Unintentional startup could result in an injury.

**! CAUTION: ENGINE FAILURE -** If the engine fails to start after 3 attempts or stops after starting; inspect and ensure that the generator is placed on horizontal surface and check the engine oil levels.

- DURING STARTING - DO NOT hold the ignition switch in the 'II' position for more than 5 seconds. It is possible that it may damage the motor. If the unit fails to start within first time. Wait 10 seconds and restart the procedure.
  - DURING OPERATION - The battery supplies power for the solenoid valve of the carburetor. When the unit is turned off, make sure that the starting switch is in the 'O' off position otherwise the battery voltage will be drained.
  - LOW OIL ALERT - If the engine is equipped with an engine oil alert, it is possible to prevent engine starting when the oil is lower than the minimum level.
  - DURING RUNNING-IN - Routinely inspect the engine oil. See maintenance section for recommended maintenance period/s.
6. Once the generator is operating stably, set the choke valve to 'OPEN' position.

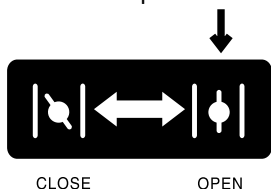

7. The generator is now ready to be used.

**! CAUTION:** When connecting the generator with electrical equipment. DO NOT start or stop the engine while electrical equipment is in their 'ON' status.

## CONNECT TO ELECTRICAL DEVICES

**⚠ WARNING:** This generator is fitted with an RCD Circuit Breaker (switch). The RCD switch will stop the voltage output when a short circuit occurs. Shutdown the generator, unplug and check the appliance before restarting.

- **ALWAYS test RCD switch before every use.**
  1. TO TEST - *Start the generator.*
  2. While the generator is running, push the 'T' button to test it works. The power to the outlets will automatically shut off.
  3. If the RCD switch does not trip, **DO NOT** use the generator. Contact your nearest service agent.

**⚠ CAUTION:** Inspect power cords for damage before using. There is a hazard of electrical shock from crushing, cutting or heat damage.

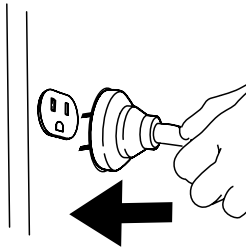

1. Allow the engine to stabilise and warm up for a few minutes after starting.
2. Make sure the electrical devices are in their 'OFF' position and the load current is not higher than the maximum withstanding current of single socket.

## MAXIMUM CAPACITY

**⚠ WARNING:** **DO NOT** overload the generator. Exceeding the capacity of generator can damage the generator and/or electrical devices connected to it.

- You must make sure your generator can supply enough rated (running) and surge (starting) watts for the electrical devices you will power at the same time. Follow these simple steps to calculate the running and starting watts necessary for your purposes.
  1. Select the electrical devices you will be powering at the same time.
  2. Calculate that the total amount of power you need to run all devices is less than the rated output of the generator.

You may need to check the items rated (running) watts in their manuals.

3. Identify how many surge (starting) watts you may need. Surge wattage is the short burst of power needed to start electric motor-driven tools or appliances such as a circular saw or refrigerator.

**⚠ CAUTION: If connected devices overheat. Immediately turn them off and disconnect from the generator.**

**⚠ NOTE: AC OVERLOAD RESET BUTTON/S - If the AC power outlet is overloaded, the AC circuit breaker will cut out the power to the device. If tripped remove device/load and reset button.**

**⚠ NOTE: Not all motors start at the same time, total surge watts can be estimated by adding only the electrical device(s) with the highest additional surge watts to the total rated watts from step 2.**

## WATTAGE REFERENCE GUIDE

ELECTRICAL EQUIPMENT	RATED POWER (W)
Tablet computer 27"	120W
Energy saving globes	5-50W
Electric Cooker	1000W
Personal Computer (standard)	100-250W
Refrigerator (standard)	50-200W
Washing Machine	700W - 2000w (heat), 500w (spin)
Electric Fan	50W
Kettle	1800W
2.0hp Air Conditioner	1800W
Electric Welding Machine	2500W
Electric Hammer	1000W
Water Generator	800W

## CHARGING A BATTERY (APPLICABLE TYPES)

**⚠ WARNING:** Batteries give off explosive hydrogen gas while recharging. An explosive mixture will remain around the battery for a long time after it has been charged. The slightest spark can ignite the hydrogen and cause an explosion, resulting in blindness or other serious injury.

- Charge the battery only with battery charging sockets provided
- Charge the battery in dry environment.

**⚠ WARNING:** DO NOT allow smoking, open flame, sparks or any other source of heat around a battery. Wear protective goggles, rubber apron and rubber gloves when working around a battery.

- Battery electrolyte fluid is an extremely caustic sulfuric acid solution that can cause severe burns. If spill occurs flush area with clear water immediately.
1. CHARGING VOLT BATTERIES - Check fluid level in all battery cells. If necessary, add ONLY distilled water to cover separators in battery cells. DO NOT use tap water.
    - If the battery is equipped with vent caps, make sure they are installed and are tight.
    - If necessary, clean battery terminals.
    - Connect battery charge cable clamp with red handle to the positive(+) battery terminal.
    - Connect battery charge cable clamp with black handle to the negative(-) battery terminal.
    - Start engine. Let the engine run while battery recharges.
    - When battery has charged, shut down engine.

**⚠ WARNING:** Use an automotive hydrometer to test battery state of charge and condition. Follow the hydrometer manufacturer's instructions carefully. Generally, a battery is considered to be at 100% state of charge when specific gravity of its fluid (as measured by hydrometer) is 1.260 or higher.

## STOPPING THE GENERATOR

**!** **WARNING: NEVER stop the engine with electrical devices connected and the connected devices turned 'ON'.**

1. Turn off all electrical equipment and disconnect all from the generator.

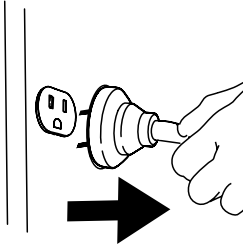

2. Allow the generator to run at no load for a few minutes to stabilize internal temperatures of the engine and generating set.
3. Press the rocker ignition switch to the 'O' off position.

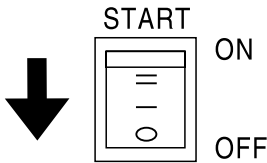

4. Turn the fuel valve to the 'OFF' position.

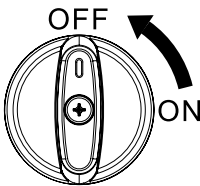

Fuel valve

## GENERAL MAINTENANCE

**!** **NOTE:** It's the operator's responsibility to complete all scheduled maintenance in a timely manner. Correct any issue before operating the generating set. Always follow the inspection and maintenance recommendations and schedules in this manual.

- Before servicing the generator, stop the generator, disconnect all electric devices and battery (if equipped) and allow the generator to cool down.

**!** **DANGER:** Accidental starts can cause severe injury or death. Remove and ground spark plug wire before performing any service.

**!** **WARNING:** Improper maintenance or failure to correct a problem before operation can cause a malfunction and result in property damage, serious injury or DEATH. Improper maintenance will void your warranty.

**!** **CAUTION:** The filter element may contain PAHs, PAHs are harmful for your health. Please wear gloves for protection during air filter maintenance.

1. MAINTENANCE SCHEDULE - Follow the service intervals indicated in the chart below. Service your generator more frequently when operating in adverse conditions.
  - Contact your local service agent for parts or engine maintenance needs.
  - See maintenance schedule on next page

		Each time before use	10 Hours or the first month (Note 2)	50 Hours or every three months (Note 2)	100 Hours or every six months (Note 2)	300 hours or every year (Note 4)
Engine oil	Inspection	✓				
	Replacement		✓		✓	
Air filter	Inspection	✓				
	Replacement			✓ (Note 3)		
Spark plug	Inspection and adjustment				✓	
	Replacement					✓
Spark arrester (Note 1)	Inspection and adjustment				✓	
Idle speed	Inspection and adjustment					✓ (Note 4)
Valve clearance						✓ (Note 4)

**!** NOTE 1: Applicable types (if available).

**!** NOTE 2: Before each season and after then (whichever comes first)

**!** NOTE 3: Service more frequently under severe, dusty, dirty conditions.

**!** NOTE 4: To be performed by an authorised service agent.

## GENERATOR MAINTENANCE

**!** WARNING: DO NOT use water to clean the generator. Water can enter the generator through the cooling slots and damage the generator windings.

**!** WARNING: DO NOT modify the generator in any way.

- DO NOT tamper with governed speed. The generator supplies the correct rated frequency and voltage when running at factory settings.
- Tampering with the factory set governor will void your warranty

## ENGINE OIL

**!** CAUTION: Oil level check - Reinstall dipstick into tube; rest on oil fill neck, DO NOT thread cap into tube.

**!** WARNING: The engine is not filled with oil at the factory. Any operation before it has been properly filled with the recommended type and amount of oil may result in engine damage and void your warranty.

1. ENGINE OIL - SAE10W-30 is recommended for general, all-temperature use. Other viscosities shown in the chart may be used when the average temperature in your area is within the indicated range.

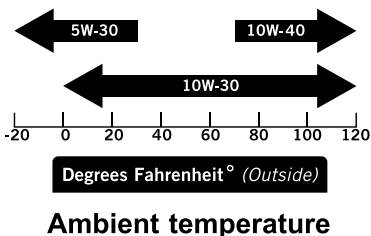

### OIL CAPACITY: 1.1L

2. ADD OIL - Place the engine on a level surface. Remove the dipstick and wipe it clean.

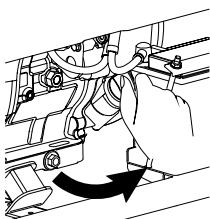

Remove dipstick

3. Add recommended oil to the upper limit.

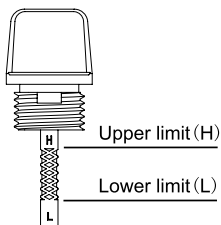



4. Remove the oil drain plug and allow the oil to drain completely.
5. Replace and fully tighten the drain plug.
6. Add recommended oil to the upper limit.
7. Reinstall and fully tighten the dipstick.
8. Dispose of used oil at an approved waste management facility.

## AIR FILTER

**! WARNING: DO NOT run the engine without the air filter, as serious damage can result.**

1. AIR FILTER - Loosen the filter fix clamp and remove the cover of the air filter.

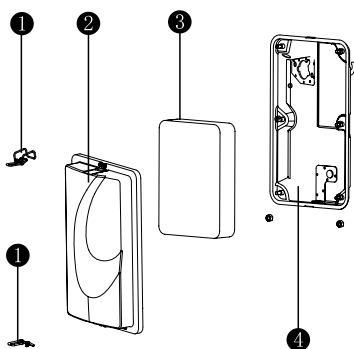

- ① Filter fix clamp
- ② Air filter cover
- ③ Foam filter element
- ④ Air filter body

2. Remove the foam filter element.
3. Wash in liquid detergent and warm water.
4. Squeeze thoroughly and dry by a clean cloth.
5. Saturate in clean engine oil.
6. Squeeze in a clean, absorbent cloth to remove all excessive oil.
7. Place the filter in the assembly.
8. Fasten the air filter cover with the fix clamp, and then mount it back to the air filter body.

## SPARK PLUG

**⚠ WARNING: Only use recommended spark plug or equivalent. DO NOT use spark plugs that have improper heat range.**

1. SPARK PLUG - Clean any dirt from the spark plug cap and spark plug base.
2. Remove the spark plug cap.
3. Using socket wrench to loosen and remove the spark plug.
4. Inspect the spark plug and spark plug washer, if it's damaged or worn, replace with a new one. Clean the spark plug with wire brush before replacing.
5. Check spark plug gap. Carefully bend side electrode to adjust the gap if necessary.

**Spark plug gap: 0.6mm - 0.8mm**

**Spark Plug tighten Torque: 15-20 N.m**

**SPARK PLUG: LG F6RTC**

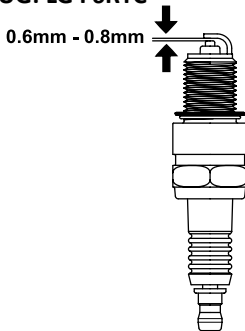

Check spark plug gap

6. Carefully thread the plug into the engine by hand.
7. After the spark plug is seated, use spark plug wrench to tighten the plug.
8. Attach the spark plug wire to the plug.
9. **Replacement spark plug: LG F6RTC**

## SPARK ARRESTER

1. SPARK ARRESTER - Fitted to exhaust outlet pipe
2. Allow the engine to cool completely before servicing the spark arrester.
3. Loosen the clamp that holds the spark arrester to the exhaust outlet.
4. Remove the spark arrester from the outlet.
5. Carefully clean the carbon deposits from the spark arrester screen with a wire brush.

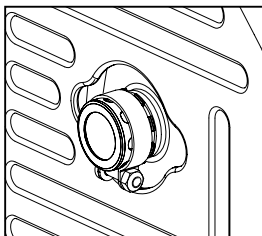

6. Replace the spark arrester if it is damaged.
7. Reinstall the spark arrester to the exhaust outlet and attach with the clamp.

## ENGINE SPEED

**⚠ WARNING: Unapproved adjustment will damage your engine and/or your electrical devices and void your warranty.**

- The speed has been set at the factory and should not require readjustment. Consult your local authorised service agent for advice.

## ADJUSTMENTS

**⚠ WARNING: Tampering with the factory set governor will damage your generator and void your warranty.**

- There is no other service and/or adjustment needed for your generator.
- Unapproved adjustments or tampering can damage your generating set and your electrical devices and will void your warranty. Contact your local dealer for such needs.

## TROUBLE SHOOTING

 **WARNING: Turn off the generator before starting maintenance work.**

FAULT	POSSIBLE CAUSE	REMEDY
Engine wont start	1. Engine switch set to 'OFF' 2. No fuel 3. Inadequate engine oil  4. No ignition.	1. Turn engine switch to the 'ON' position 2. Fill tank as per instructions 3. Check oil level. This engine is equipped with a low oil sensor. The engine cannot be started unless the oil level is above the prescribed lower limit. 4. Remove the spark plug cap. Clean any dirt from around the plug base, then remove the spark plug. Install the spark plug in the plug cap. Turn the engine switch "ON". Grounding the electrode to any engine ground, pull the recoil starter to see if sparks jump across the gap. If there is no spark, replace the plug. Reinstall the plug and start engine according to instructions in this manual. Consult Customer Service if necessary.
Generator has no output	1. No power. 2. Inadequate power cord or extension cord	1. Reset circuit breakers and RCD. 2. Check the cord for damage and the extension cords capabilities

 **NOTE: If a problem is still exists, contact with your local authorised dealer for advice.**

## STORAGE AND TRANSPORT

 **DANGER: FIRE OR EXPLOSION - Gasoline is highly flammable and extremely explosive. Empty the fuel tank and shut off fuel valve before storing or transporting this generator.**

1. STORAGE - The generator should be started at least once every two weeks and allowed to run for at least 20 minutes. Follow the instructions below for longer term storage if the generator is not used for 2 months or more.
2. LONG TERM STORAGE - Follow the instructions below for if the generator is not being used with in the next 2 months or longer.
  - i. Allow the generating set to cool completely before storage.
  - ii. Clean the generating set according to the instructions in the Maintenance section.
  - iii. Drain all fuel completely from the fuel hose and carburetor to prevent gum from forming.
  - iv. Turn off the fuel supply at the fuel valve.

- V. Change the oil.
  - Vi. Remove the spark plug and pour about 15 ml of oil into the cylinder. Crank the engine slowly to distribute the oil and lubricate the cylinder.
  - Vii. Reattach the spark plug.
  - Viii. Store the unit in a clean, dry area out of direct sunlight.
3. TRANSPORTATION - To prevent fuel spillage, when transporting or during temporary storage, the generator should be secured upright in its normal operating position, with the all switches in the OFF position.



**DANGER: Do not overfill the tank. Do not operate the generator while it is on a vehicle. Take the generator off the vehicle and use it in a well-ventilated place.**

- Avoid a place exposed to direct sunlight when putting the generator on a vehicle.
- If the generating set is left in an enclosed vehicle for many hours, high temperature inside the vehicle could cause fuel to vaporize resulting in a possible explosion.
- Do not drive on a rough road for an extended period with the generating set on board. If you must transport the generating set on a rough road, drain the fuel from the generating set beforehand.

For any questions regarding operation or maintenance, please consult your local service agent. Find your local service agent at [www.crommelins.com.au](http://www.crommelins.com.au).





